

# Merseyside Fire & Rescue Service

## 1. Calculating Occupancy in Places of Assembly

The following information has been extracted from the CLG guide for Fire Safety Risk Assessment in Small and Medium Places of Assembly under the Regulatory Reform (Fire Safety) Order 2005 (this guide is available to download free from <https://www.gov.uk/workplace-fire-safety-your-responsibilities/fire-safety-advice-documents>) and Building Regulations Approved Document B (ADB).

The information is provided as simple methodology to assist Responsible Persons and Licensing Authorities arrive at a safe occupancy level for a premises. It should be noted that there are alternative methods; however these generally require a greater understanding of fire engineering practices and guidance.

As escape routes need to be adequate for the number of people likely to use them, you will first need to consider the largest number of people, including staff, public and outside contractors that may be present at any one time. For some events the maximum numbers of people likely to be present will be known, e.g. where the event is ticketed or limited by seating. If occupant numbers are not known or a suitable limit is required for your fire risk assessment or Licensing application, then this simple calculation method can be used.

The occupancy figure for any building is based on the **lesser** of the two following calculations;

1. The number of persons who can safely reside in the premises. Using the floor space factor below will assist in working this out. Number of people = Floor area (m<sup>2</sup>) / Occupant density
2. The width and capacity of the exit routes to allow people to escape safely. (See 3. Escape route capacity)

| <b><u>Floor Space Factor</u></b>                     |   |
|--|---|
| Occupied Area Type                                   | Typical Occupant Density m <sup>2</sup> /person |
| Standing spectator/audience area or *bar area        | 0.3   |
| Assembly area, public house, dance floor or hall etc | 0.5   |
| Dining area or restaurant                            | 1.0   |
| Sports area  | 2.0   |
| Shop sales area                                      | 2.0   |
| Display, production or workshop area                 | 5.0   |
| Office   | 6.0   |
| Shop (bulky goods) sales area                        | 7.0   |

*\*Note - Bar area is usually within 2m of a serving point. Further from the bar the occupancy for the main use of the room should be used eg assembly area.*

*Floor areas should consider useable space i.e. spaces where persons reside. Toilets, corridors and stairways do not count as useable space.*

## Alternative Escape Routes

For a normal risk premises if **more than 60 people** are present, or an exit cannot be reached in 18m from anywhere in the room, then a **minimum of two separate exits** are required. For two exits from a room to be considered alternative they should be located **at least 45° apart**. This prevents having to walk directly towards a fire when there are large numbers of people present or long escape routes.

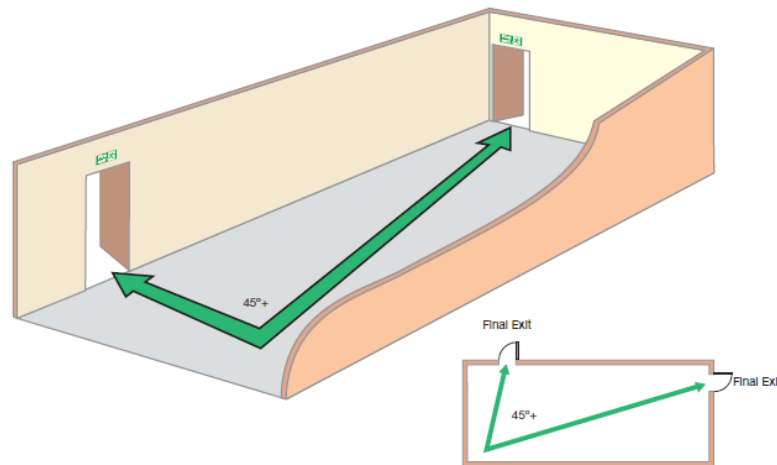

*NB. Ideally all doors on escape routes should open in the direction of escape; this is particularly important if more than 60 people are intended to use them. A single inward opening door would limit capacity to 60 persons.*

## 2. Calculating Escape Route Capacity

Once you have calculated the occupancy for the size of the premises you must check that this is below the maximum numbers the escape routes can accommodate. Reasonable escape times are 2½ minutes for normal risk premises. Most places of assembly fall into this normal risk category. The following can be used to determine the general capacities of escape routes within this time:

A clear width of at least 750mm can accommodate up to 100 people in normal risk premises.

In most places of assembly the minimum width of an escape route should ideally be 1050mm but in any case not less than 750mm (unless it is for use by less than five people in a separate part of your premises).

A width of at least 1050mm can accommodate up to 200 people in normal risk premises. Thereafter an additional 75mm is required for each additional 15 persons (or part of 15).

*NB Where wheelchair users are present then the minimum width should not be less than 900mm.*

As a general rule stairways should be at least 1,050mm wide and their capacity should be sufficient to accommodate the number of people on the floors using them. For existing premises the width and number of staircases may limit the safe numbers of upper floors regardless of the calculations for available floor space and exit width for that floor, all exit routes are governed by their narrowest part.

When calculating the overall available escape route capacity for premises that have more than one way out you should assume that the widest exit is not available, because it has been compromised by fire. The maximum occupancy should then be limited to that accommodated by the aggregate width of the remaining escape routes. The exit capacity must be greater than or the same as the number of occupants.

E.g.

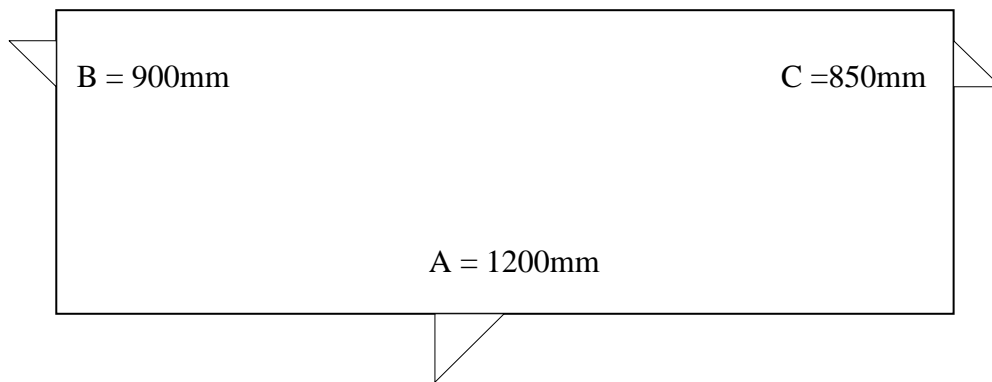

- Exit A (1200mm wide) =  $200 + 30 (150\text{mm over } 1050\text{mm}) = 230$  persons,
- Exit B (900mm wide) = 100 persons
- Exit C (850mm wide) = 100 persons
- Maximum exit capacity,  $A+B+C = 430$  persons
- Discount the largest Exit (A) 230 persons
- **Total safe exit capacity is Exit B + Exit C = 200 persons**

### **3. Seating & Gangways**

Seating should be arranged to allow free and ready access direct to the exits. In fixed seating there should be a clear space of at least 305mm between rows. Gangways should be adequate for the number of seats served (see previous escape route capacity) and at least 1,050 mm wide. In general, no seat should be more than seven seats away from a gangway. If temporary seating is provided these should be secured in lengths of not fewer than four seats and not more than twelve.

### **Further Help & Advice**

The Government has produced the following guides that further explain the risk assessment process and give some advice on what arrangements may be suitable to protect your premises.

**Small & Medium Places of Assembly:** This guide is intended for premises where the main use of the building or part of the building is as a small (i.e. premises accommodating up to 60 people) or a medium (i.e. premises accommodating up to 300 people) place of assembly. These usually include public houses.

**Large Places of Assembly:** This guide is intended for premises accommodating more than 300 people.

Both guides can be downloaded for free from:

<https://www.gov.uk/workplace-fire-safety-your-responsibilities/fire-safety-advice-documents>

These guides have been written to provide guidance for a responsible person, to help them to carry out a fire risk assessment in less complex premises. If you read the guide and decide that you are unable to apply the guidance, then you should seek expert advice from a competent person. More complex premises will probably need to be assessed by a person who has comprehensive training or experience in fire risk assessment.

## Worked Example

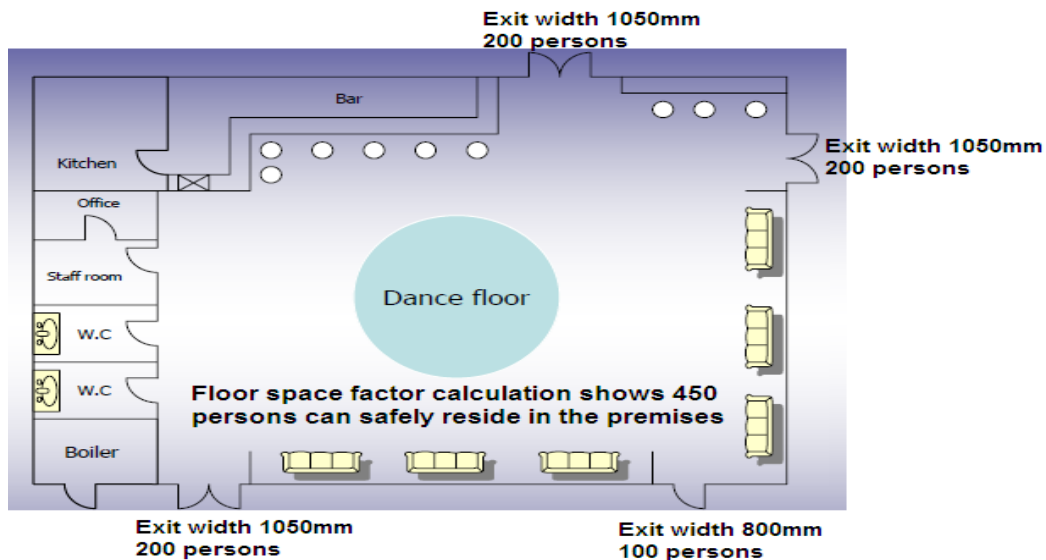

### Floor space calculation

Bar area -  $2\text{m} \times 15\text{m} / 0.3 = 100$

Assembly area -  $166\text{m}^2 / 0.5 = 332$

Seating - 18

**Total = 450 people**

### Escape route capacity

Using the exit width calculations (without discounting an exit) exit capacity is 700.

**Always assume the worst case for the discount of exit(s), lost due to fire.**

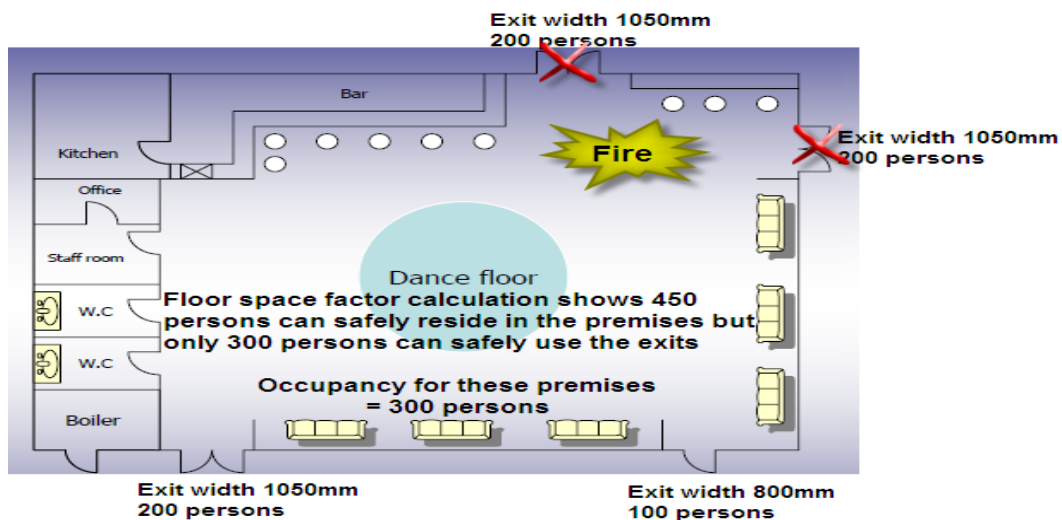

Calculate the total exit capacity after discounting the largest exit (or exits in the case of ones that are close together) in this case 2 exits for 200 persons each are close together so their total is discounted  $700 - 400 = \mathbf{300 \text{ persons total exit capacity}}$ .

The lowest figure from the 2 calculations, **300** is the safe occupancy of the premises in this case therefore the fire risk assessment should indicate this, particularly for Licensed premises.